

- Etched polypropylene face
- Face anchored in concrete
- Ultra-violet inhibitor
- Exceeds ASTM-D1693 Standards for Environmental Stress Cracking Resistance
- Meets Caltrans #3 1/2 State Specifications

REINFORCED CONCRETE LID

NO. N09T

20 lbs.

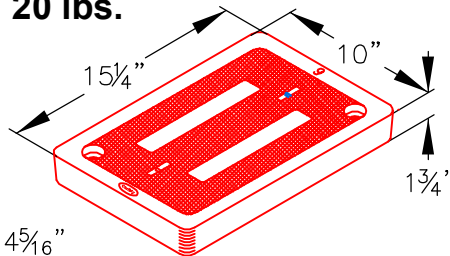

ELECTRICAL BOX

No. N09BOX

90 lbs.

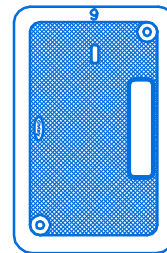
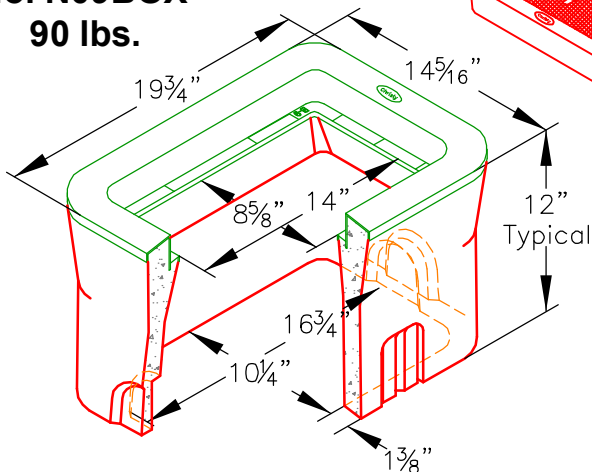

N09J

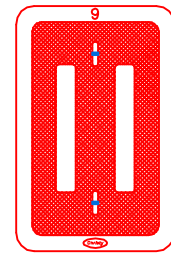

N09D

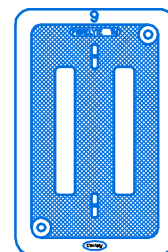

FL09T

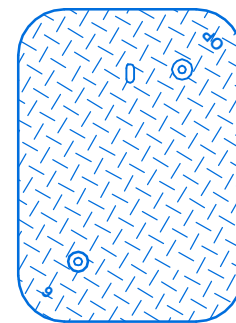

N09-61J

A high density reinforced concrete pull and junction box with end and side knockouts. Non-setting shoulders maintain grade and facilitate back filling. Approximate dimensions and weight shown.

Ordering Code	Item	Approx. Shipping Weight	Description
N09BOX	BOX	90	N09 Electrical Box (10 1/4" x 16 3/4")- Meets #3-1/2 State Specifications- 28 per pallet
N09D	LID	20	Reinforced concrete
FLO9D	LID	9	Fibrelite lid, non-concrete
N09T	LID	20	Reinforced concrete, bolt down (order N99 bolts separately)
FL09T	LID	9	Fibrelite lid, bolt down (order N99 bolts separately)
N09J	LID	22	Cast iron, bolt down (order N99 bolts separately)
B09-61D	COVER	22	Steel checker plate
N09-61J	COVER	22	Steel checker plate, bolt down (order N99 bolts separately)
B09X12	EXTENSION	87	12" Reinforced concrete - 28 per pallet
B09SL	SLAB	32	Reinforced concrete (12 3/4" x 19 3/4")

Galvanizing available on all steel covers



Oldcastle Precast®
Enclosure Solutions

MADERA/TRACY/ROSEVILLE/PHOENIX
Phone: (800) 486-7070 Fax: (800) 486-6804
Copyright © 2009 Oldcastle Precast Inc.

N09 BOX

FILE NAME: N09_ISO

ISSUE DATE: January, 2009

www.oldcastleprecast.com

N09 ELECTRICAL BOX

10-1/4" x 16-3/4"

