

**BICYCLE BLOCK
No. M20W8BYC
100 lbs.**

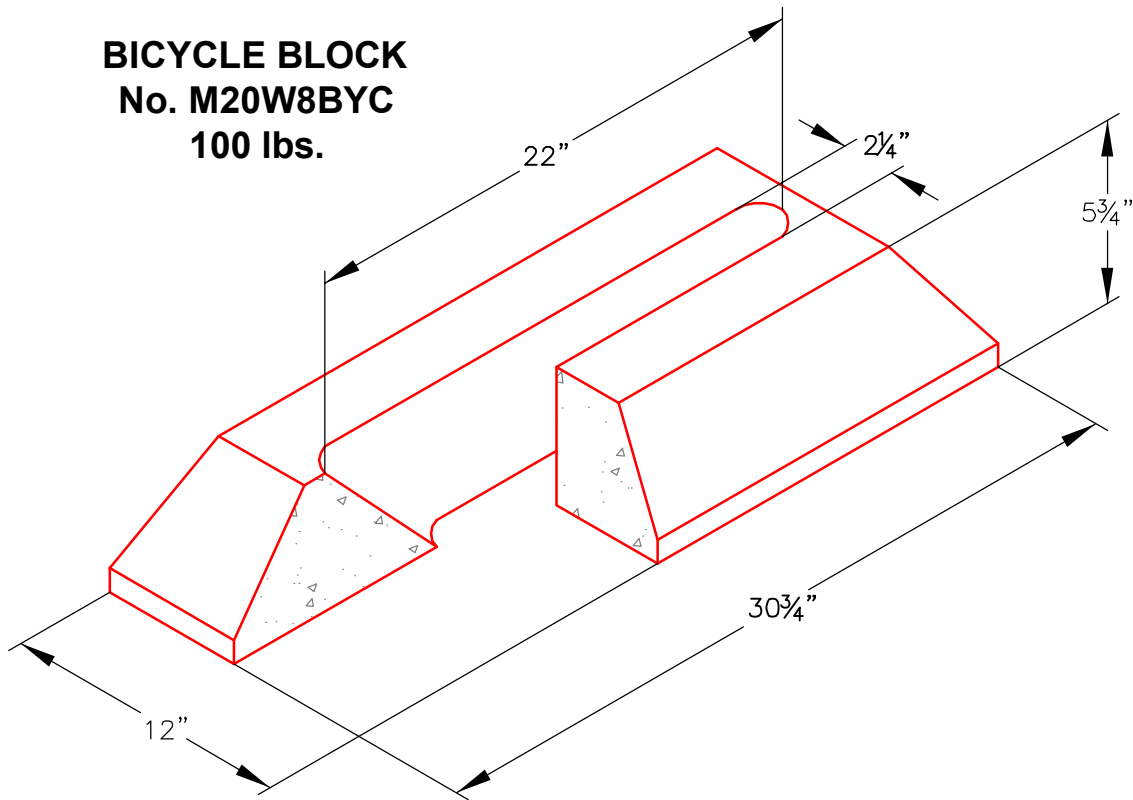

A specifically designed bumper block for use in school campuses, shopping centers, apartments, playgrounds, ect. Made of reinforced concrete to withstand constant use and rough service. A 1" locking eye bolt will accommodate either steel chain or cable when used with a lock. Can be installed with epoxy adhesive for permanent installation or without for non-permanent use. will permit bicycle to stand in a vertical position without special blocking. Approximate dimensions and weight shown.

Ordering Code	Item	Approx. Shipping Weight	Description
M20W8BYC	BICYCLE	100	W8 Bicycle Block with locking eye bolt



Oldcastle Precast®
Enclosure Solutions

MADERA/TRACY/ROSEVILLE/PHOENIX
Phone: (800) 486-7070 Fax: (800) 486-6804
Copyright © 2009 Oldcastle Precast Inc.

BICYCLE BLOCK

FILE NAME: 20W8BYCBLOCK_ISO

ISSUE DATE: January, 2009

www.oldcastleprecast.com

BICYCLE BLOCK

