

**SYNERTECH LID
No. SYN3048T
214 lbs.**

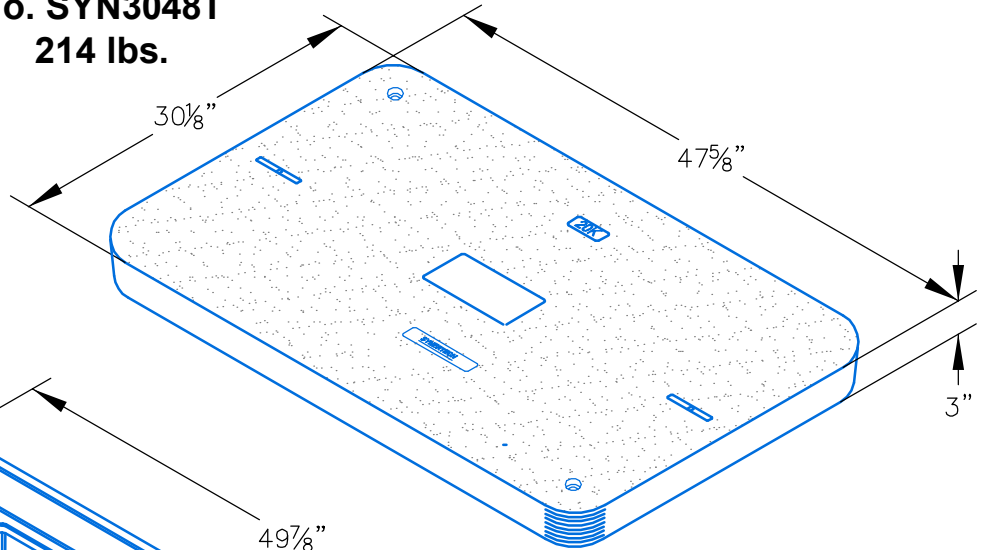

**SYNERTECH BOX
No. SYN3048T-18
(STRAIGHT WALL)
108lbs.**

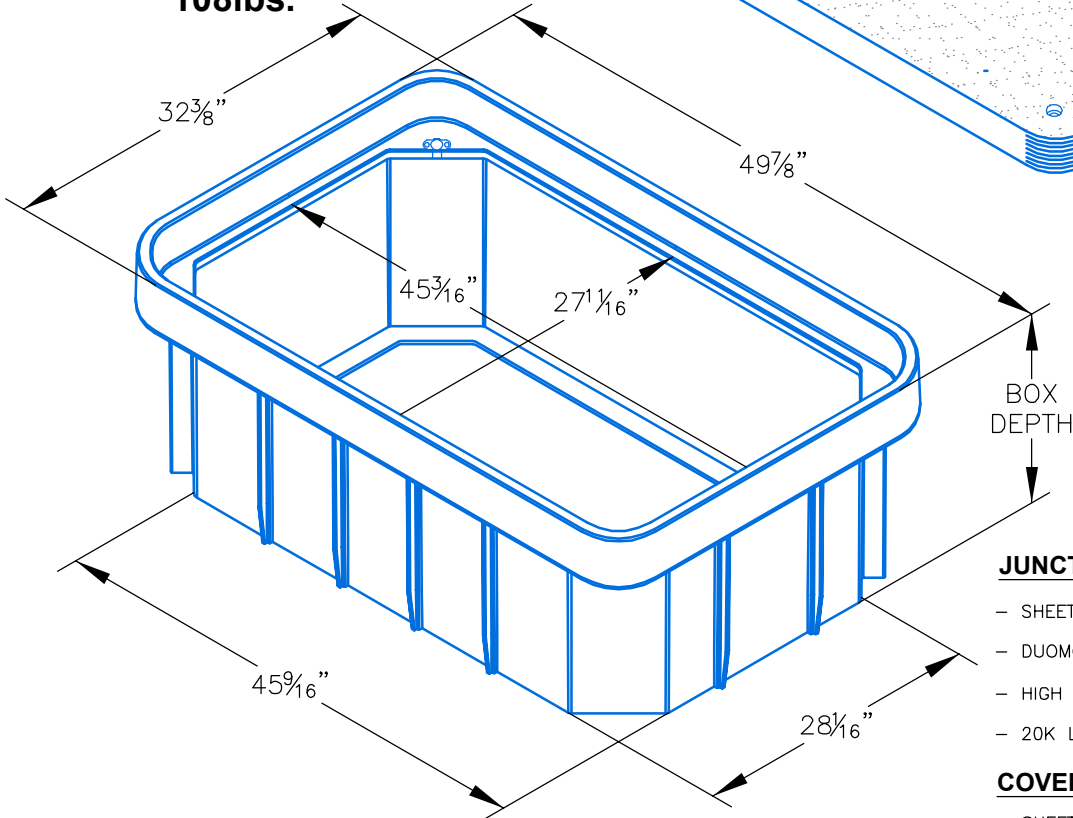

JUNCTION BOX FEATURES

- SHEET MOLDING COMPOUND (SMC) BODY.
- DUOMOLDING CONSTRUCTION.
- HIGH DENSITY POLYMER CONCRETE (HDPC) RING.
- 20K LOAD RATING

COVER FEATURES

- SHEET MOLDING COMPOUND (SMC) LINING.
- DUOMOLDING CONSTRUCTION.
- HIGH DENSITY POLYMER CONCRETE (HDPC).
- 20K LOAD RATING

Ordering Code	Item	Approx. Shipping Weight	Description
SYN3048T	LID	214	Synertech Lid, bolt down (order bolts separately)
SYN3048TBOX18DUO	BOX	108	Box - Open Bottom/18" Straight Wall (Shown Above)
SYN3048TBOX24DUO	BOX	122	Box - Open Bottom/24" Straight Wall
SYN3048TBOX36DUO	BOX	235	Box - Open Bottom/36" Straight Wall



Oldcastle Precast®
Enclosure Solutions

MADERA/TRACY/ROSEVILLE/PHOENIX
Phone: (800) 486-7070 Fax: (800) 486-6804
Copyright © 2008 Oldcastle Precast Inc.

SYN 3048T BOX-DUO

FILE NAME: SYN3048DUO_ISO

ISSUE DATE: January, 2008

www.oldcastleprecast.com

**3048 JUNCTION BOX
(STRAIGHT WALL)**

SYNERTECH