

"A" DIA	"B"	"C" (MAX)	WT. PER LINEAR FT.
96"	9"	6'-0"	3,080#
120"	10"	4'-11"	4,185#
144"	12"	3'-4"	5,970#

**NOTES:**

1. MANHOLE SECTIONS ARE DESIGNED TO MEET ASTM C478.
2. OPENINGS MAY BE SIZED AND LOCATED AS REQUIRED.
3. FOR OPTIONAL ACCESSORIES CHECK ACCESSORIES / HARDWARE SECTION.
4. AVAILABLE WITH FLOOR.
5. 96" HOLDS 370 GALLONS, 120" HOLDS 580 GALLONS, 144" HOLDS 830 GALLONS PER FOOT.

MH240

05/08

**LARGE MANHOLE SECTIONS**

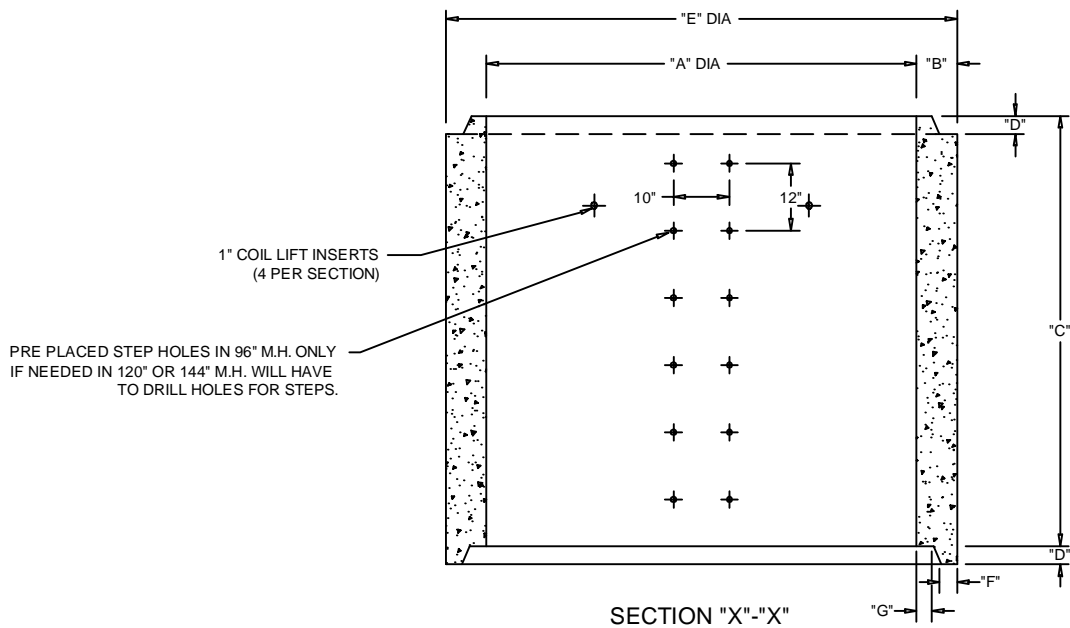
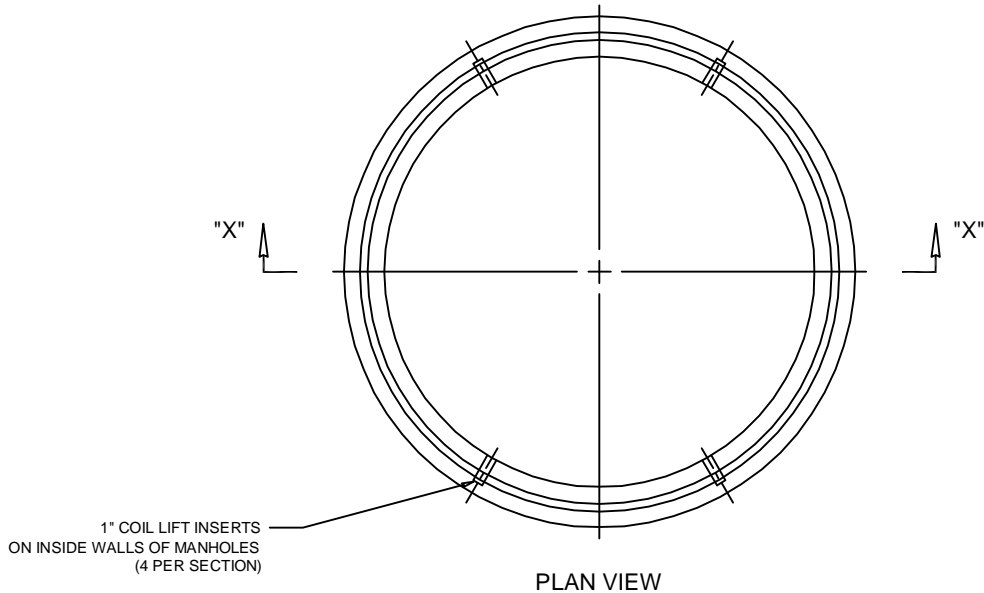

"A" DIA	"B"	"C" (MAX)	"D"	"E"	"F"	"G"
96"	9"	6'-0"	4 3/4"	114"	3 1/2"	4 1/2"
120"	10"	4'-11"	2 3/4"	140"	4 1/4"	4 1/4"
144"	12"	3'-4"	2 1/2"	168"	5 1/4"	5 3/4"

**LARGE MANHOLE SECTIONS**

MH240

05/08  
Back Page