

PLAN VIEW

GENERAL NOTES:

1. Concrete: 28 Day Compressive Strength $f'_c = 4,500$ psi
2. Steel Reinforcement: ASTM A-615, Grade 60
3. Cover to Steel-1" Minimum
4. Designed to Meet ASTM C858 and ACI 318 for HS-20-44 Loading
5. Earth Cover-0 to 2 Feet
6. Joint Sealant: Conseal Butyl Sealant ASTM C-990-91
7. Weight: Top - 4050#
Btm - 4575#

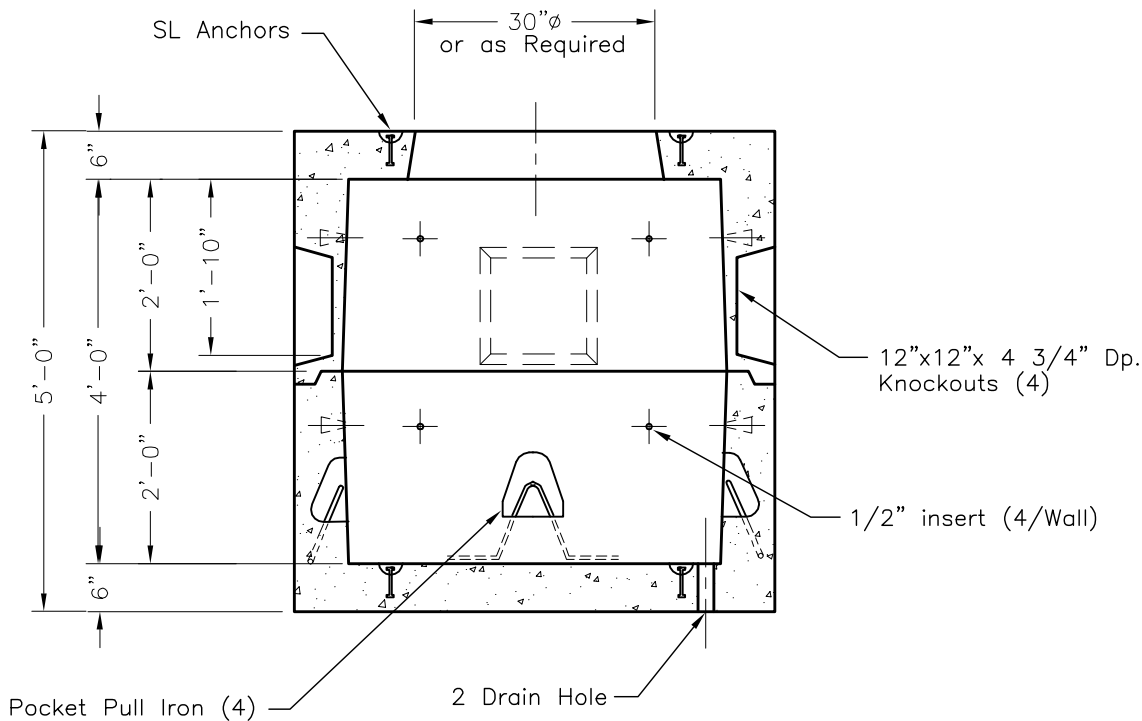

SECTION VIEW A-A

SCALE: 1/2" = 1'-0"



747 Allenridge Point, Lexington, KY 40510
Phone: 859-259-1484 Fax: 859-233-9351

UEP444PB

FILE NAME: 384UEP444PB.DWG

ISSUE DATE: January, 2004

www.oldcastleprecast.com

**4' x 4' x 4' I.D.
Pull Box**

THIS DOCUMENT IS THE PROPERTY OF OLDCASTLE PRECAST. IT IS SUBMITTED FOR REFERENCE ONLY AND SHALL NOT BE USED IN ANY WAY INJURIOUS TO THE INTERESTS OF SAID COMPANY. COPYRIGHT 2007 Oldcastle Precast, Inc. All Rights Reserved.