

PLAN VIEW

GENERAL NOTES:

1. Concrete: 28 Day Compressive Strength $f'_c = 4,500$ psi.
2. Reinforcing: ASTM A-615, Grade 60.
3. Joint Sealant: Butyl Rubber SS-S-00210.
4. Designed for Maximum Soil Cover of 5'-0" Above Box.
5. Supports an H2O Loading as Indicated by AASHTO.

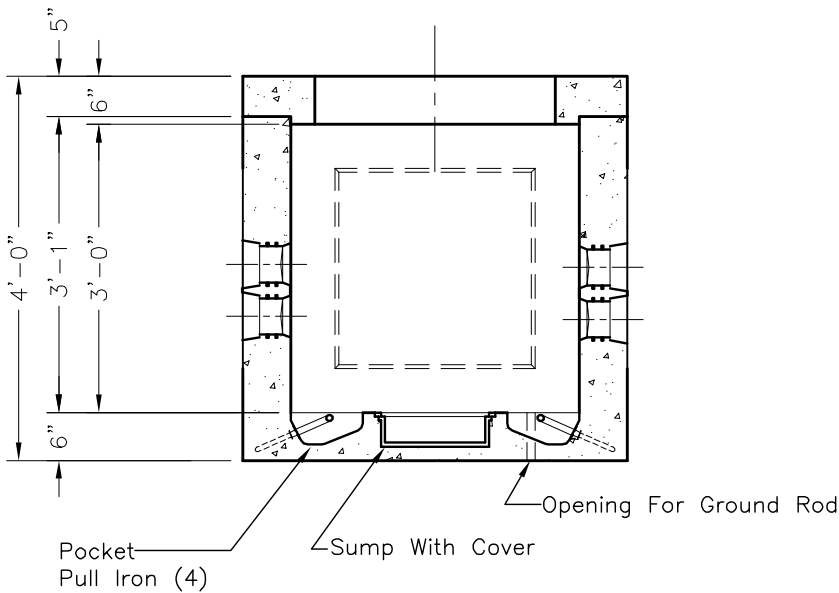

SECTION A-A

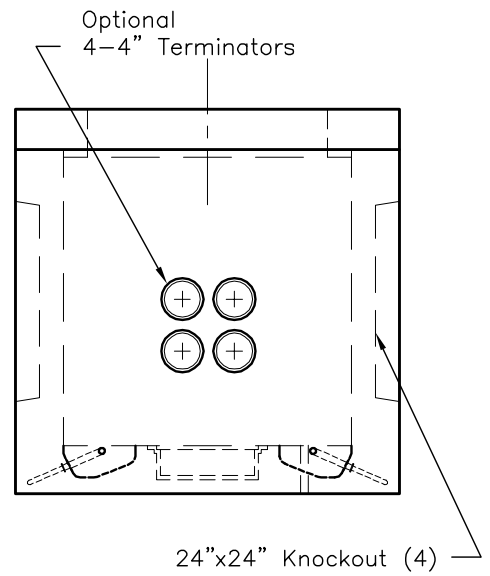

ELEVATION B-B

SCALE: 1/2" = 1'-0"



747 Allenridge Point, Lexington, KY 40510
Phone: 859-259-1484 Fax: 859-233-9351

UEP333PB

FILE NAME: 384UEP333PB.DWG

ISSUE DATE: January, 2002

www.oldcastleprecast.com

**3'-0" x 3'-0" x 3'-0" I.D.
Pull Box**

THIS DOCUMENT IS THE PROPERTY OF OLDCASTLE PRECAST, IT IS SUBMITTED FOR REFERENCE ONLY AND SHALL NOT BE USED IN ANY WAY INJURIOUS TO THE INTERESTS OF SAID COMPANY. COPYRIGHT 2007 Oldcastle Precast, Inc. All Rights Reserved.

UT-095