

PLAN VIEW

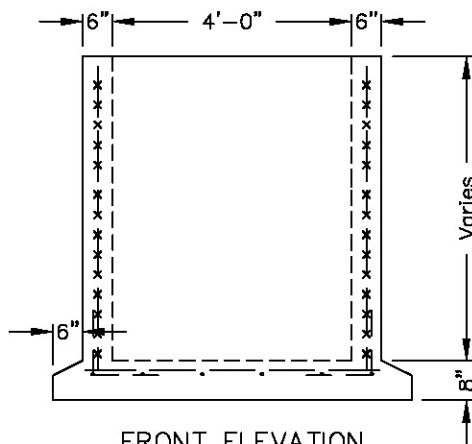

FRONT ELEVATION

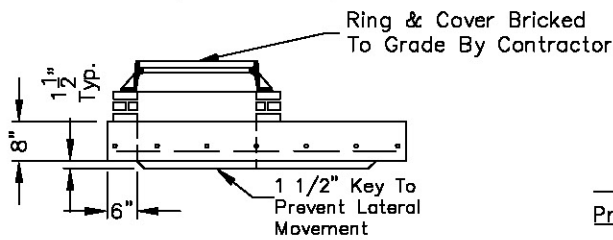
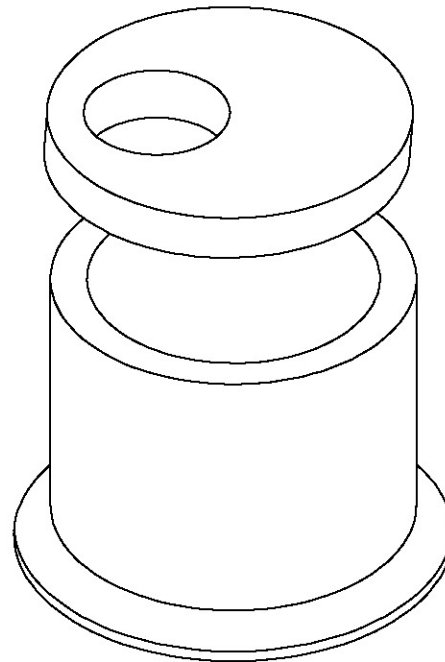

ISOMETRIC VIEW

Product Specification:

- Concrete = 4000 PSI At 28 Days
- Type II Cement
- Reinforcement Steel Grade 60:
- Top Slab = #5 @ 10" O.C.E.W.
Extra #5 Around Lid Opening
- Wall = 3x8 W3/W2
- Base Slab = #5 @ 10" O.C.E.W.

Structure Weight:

- Top Slab = 1,793 LBS. .90 Tons
- Wall = 1,025 LBS./V.Ft.
- Bottom Slab = 2,747 LBS., 1.37 Tons

Bottom Slab & Wall Are Poured Monolithically.

Various Lid Openings Are Available To Accommodate Larger Rings And Covers When Specified. Openings Will Be Centered Or Offset As Specified.



U.S. FOUNDRY & MFG. CORP. RING & COVERS *Or Approved Equal*

U.S.F. NO.	Clear Opening	Load Rating	Total Weight
170 XB	22 1/2"	Heavy Duty	340
310 A	20 3/4"	Heavy Duty	530
420 C	20 5/8"	Heavy Duty	405

O—Ring Available For All Rings As Listed Above.
See U.S. Foundry Catalog For Other Rings & Covers.

Florida Plant Locations:

Orlando

690 W. Taft—Vineland Rd., Orlando, Fl. 32824
Phone: 407-855-7580 Fax: 407-768-8428

Jacksonville

5995 Soutel Drive, Jacksonville, Fl 32219
Phone: 904-768-7081 Fax: 904-768-8428

Brooks Products—Medley

7311 N.W 77th Street, Medley, Fl 33166
Phone: 305-887-3527 Fax: 305-887-7119

Marianna

4043 Family Dollar Parkway, Marianna, Fl 32448
Phone: 850-482-5830 Fax 866-850-9049

Cape Coral

2140 Pondella Rd, Cape Coral, Fl. 33903
Phone: 239-574-8896 Fax: 239-574-9517



Oldcastle Precast® Inc.

P-7

www.oldcastleprecast.com

Type P-7 (Alt-A)
Storm Manhole
FDOT Index 200 & 201

Copyright © 2003 Oldcastle Precast, Inc.