

DESIGN NOTES:

1. Concrete : 5,000 P.S.I  
Minimum Strength @ 28 Days
2. Steel Reinforcing- ASTM A-615,  
Grade 60.
3. Cover to Steel-1" Minimum
4. Tanks are Designed to Meet ASTM  
C858 and ACI 318 with AASHTO  
HS-20 Loading
5. Earth Cover -0 to 5 Feet Max.
6. Construction Joint-Sealed with  
1" Dia Butyl Rubber or Equivalent

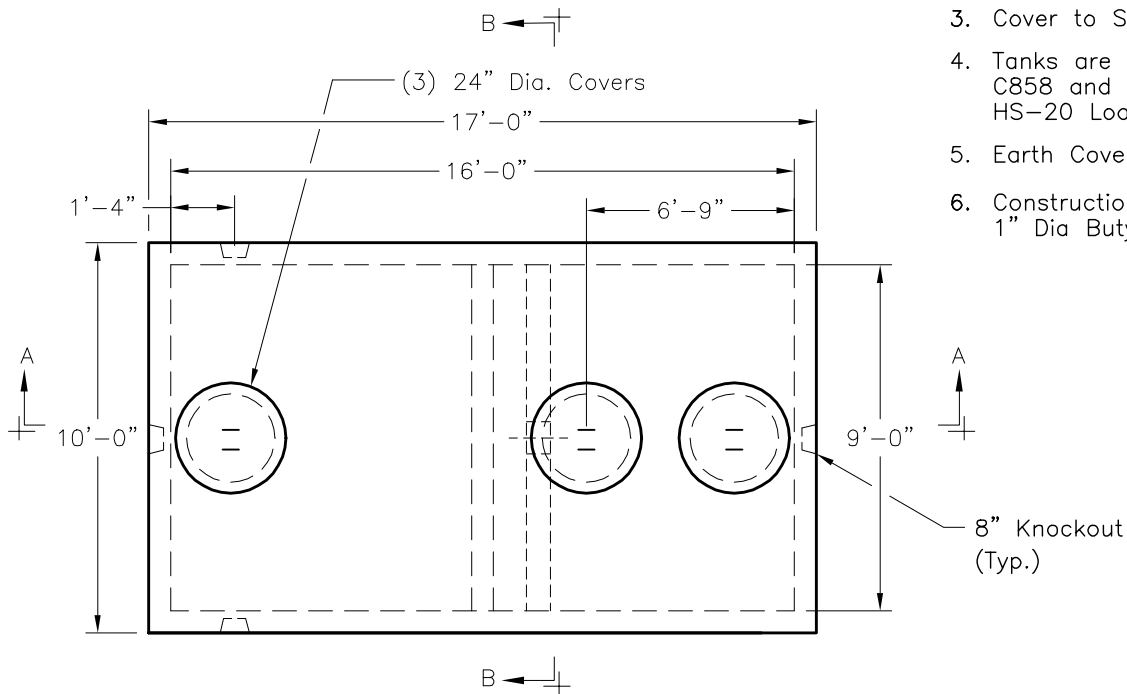

**PLAN VIEW**

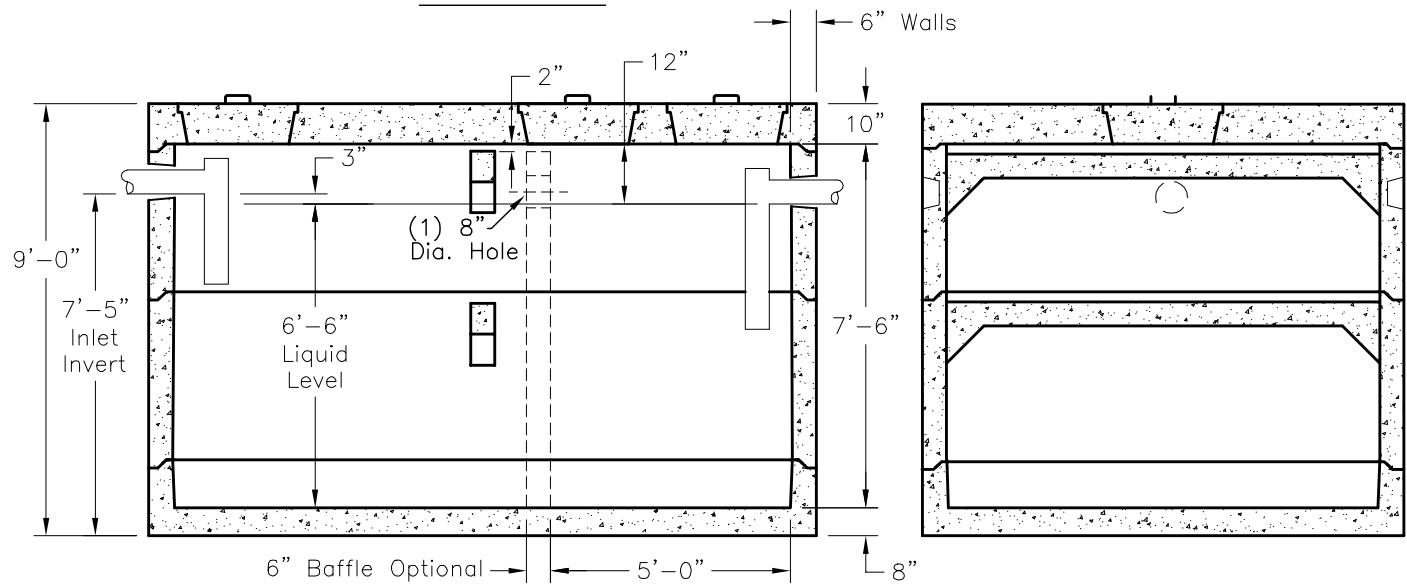

**SECTION A-A**

**SECTION B-B**



**Oldcastle Precast®**

**CST-7000**

FILE NAME: 324ESCCST7000\_DET.DWG

ISSUE DATE: January, 2008

[www.oldcastleprecast.com](http://www.oldcastleprecast.com)

**9'-0" x 16'-0" x 7'-6" I.D.  
Septic Tank  
7,000 Gallon Capacity**

Copyright © 2008 **Oldcastle Precast®**